

# SM2082G

## Feature

- ◆ Our patented constant current control technology , the output current deviation between chips is  $\leq \pm 4\%$
- ◆ Input voltage: 120V ac /220V ac
- ◆ Support thyristor dimming application circuit
- ◆ With over-temperature adjustment function
- ◆ The chip can share the PCB board with the LED
- ◆ Simple wiring and low cost
- ◆ Package form: TO252-2, SOT89-3

## Application

- ◆ filament lamp
- ◆ LED bulbs, downlights, etc.
- ◆ Other LED lighting applications

## Description

SM2082G is a single-channel LED linear constant current control chip. The chip uses the company's patented constant current setting and control technology. The output current is set by an external Rext resistor, and the output current does not change with the chip OUT port voltage. It has good Constant current performance.

The chip has an over-temperature adjustment function. When the chip temperature reaches the over-temperature adjustment point, the output current gradually decreases, which protects the chip and improves application reliability. The system structure is simple, there are very few peripheral components, and the solution cost is low.

## Pin diagram

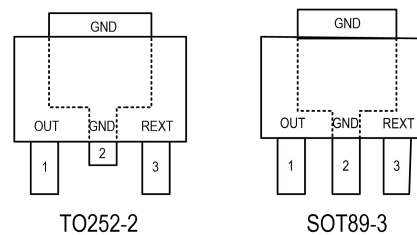

## Typical Application

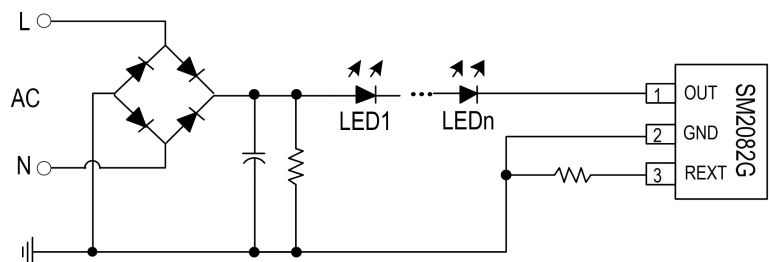

Note: The power supply in the above picture can be AC power supply or DC power supply.

## Internal Function Diagram

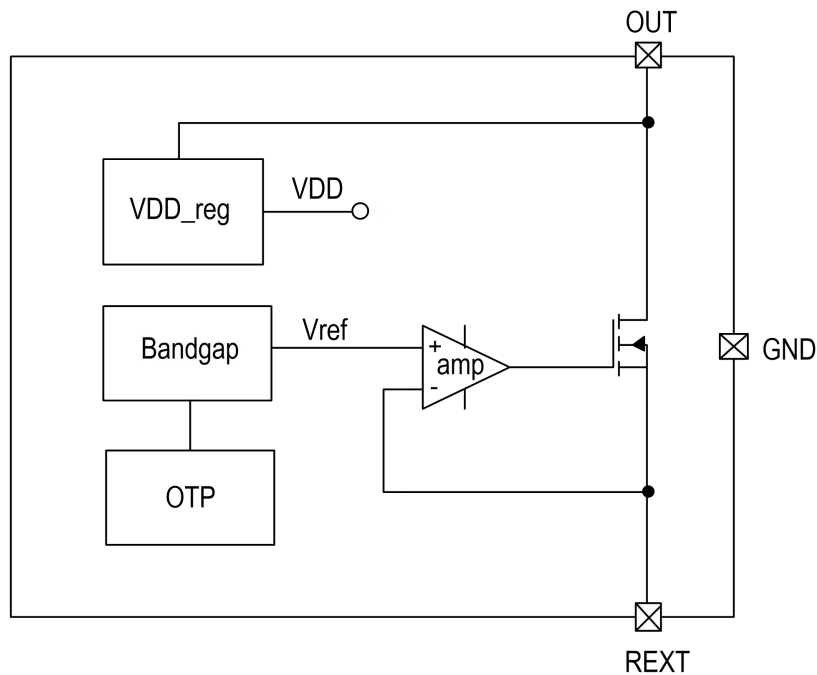

## Pin Description

TO252-2/SOT89-3		
Pin number	Pin name	Pin description
1	OUT	Power input and constant current output port
2	GND	chip ground
3	REXT	Output current value setting port

## Order Information

Type	Package	Packing		Reel size
		Tube	Tape	
SM2082G	TO252-2	40,000 pieces/box	3000 pieces/plate	13 inches
	SOT89-3	/	4 000 pieces/plate	13 inches

## Absolute Maximum Parameter (Note 1)

Unless otherwise stated,  $T_A=25^{\circ}\text{C}$ .

Symbol	Description	Range		Unit
$V_{\text{OUT}}$	OUT voltage	-0.5~500		V
$V_{\text{REXT}}$	REXT voltage	-0.5~8		V
$R_{\theta\text{JA}}$	PN junction to ambient thermal resistance (Note 2)	TO252-2	55	$^{\circ}\text{C/W}$
		SOT89-3	105	
$P_{\text{D}}$	Power consumption (Note 3)	TO252-2	1.8	W
		SOT89-3	1	
$T_{\text{J}}$	Operating junction temperature	-40~150		$^{\circ}\text{C}$
$T_{\text{STG}}$	Storage temperature	-55~150		$^{\circ}\text{C}$
$V_{\text{ESD}}$	HBM ESD	2		KV

Note 1: The maximum output power is limited to chip junction temperature, the maximum limit means that the chip can be damaged beyond the scope of the work. The maximum limit value is the work in the limit parameter range, the device function is normal, but it is not completely guaranteed to meet the individual performance indexes.

Note 2:  $R_{\theta\text{JA}}$  measures the flow of water according to the JEDEC JESD51 thermal measurement standard on the single-layer thermal conductivity test board under  $T_A=25^{\circ}\text{C}$ .

Note 3: The maximum power consumption is decreased when temperature rising, this depends on  $T_{\text{JMAX}}$ ,  $R_{\theta\text{JA}}$  and  $T_A$  Maximum allowable power consumption is  $P_{\text{D}} = (T_{\text{JMAX}}-T_A) / R_{\theta\text{JA}}$  or the lower value of the value given in the limit range.

## Electric Operating Parameter (Note 4、5)

Unless otherwise stated,  $T_A=25^{\circ}\text{C}$ .

Symbol	Description	Condition	Min.	Typ.	Max.	Unit
$V_{\text{OUT\_MIN}}$	constant current inflection point	$I_{\text{OUT}}=30\text{mA}$	-	-	6.5	V
$V_{\text{OUT\_BV}}$	OUT port voltage resistance	-	500	-	-	V
$I_{\text{OUT}}$	OUT output current	-	5	-	120	mA
$I_{\text{DD}}$	Quiescent Current	$V_{\text{OUT}}=2.0\text{V}$ , REXT floating	0.09	0.125	0.160	mA
$V_{\text{REXT}}$	REXT port voltage	$V_{\text{OUT}}=15\text{V}$	0.576	0.600	0.624	V
$D_{\text{IOUT}}$	IOUT inter-chip deviation	$I_{\text{OUT}}=3.0\text{mA}$	-	$\pm 4$	-	%
$T_{\text{SC}}$	Current negative temperature compensation starting point (Note 6)	-	-	145	-	$^{\circ}\text{C}$

Note 4: Electrical operating parameters define the DC and AC parameters of the device within the operating range and under test conditions that guarantee specific performance indicators. For parameters without given upper and lower limits, the specification does not guarantee their accuracy, but their typical values reasonably reflect device performance.

Note 5: The minimum and maximum parameter ranges in the specification are guaranteed by testing, and the typical values are guaranteed by design, testing or statistical analysis.

Note 6: The starting point of current negative temperature compensation is the chip internal set temperature of  $145^{\circ}\text{C}$ .

## OUT Output Current Characteristic

SM2082G's OUT port output current calculation formula:  $I_{OUT} = \frac{V_{REXT}}{R_{ext}} = \frac{0.6V}{R_{ext}(Q)}$  (A).

Where  $V_{REXT}$  is the REXT port voltage,  $R_{ext}$  is the REXT port resistance.

## Over temperature adjustment function

When the internal temperature of LED lamps is too high, it will cause serious light decay in the LED lamps and reduce the service life of the LEDs. SM2082G integrates a temperature compensation function. When the internal temperature of the chip reaches 145 °C , the chip will automatically reduce the output current to reduce the internal temperature of the lamp.

## System Scheme Design

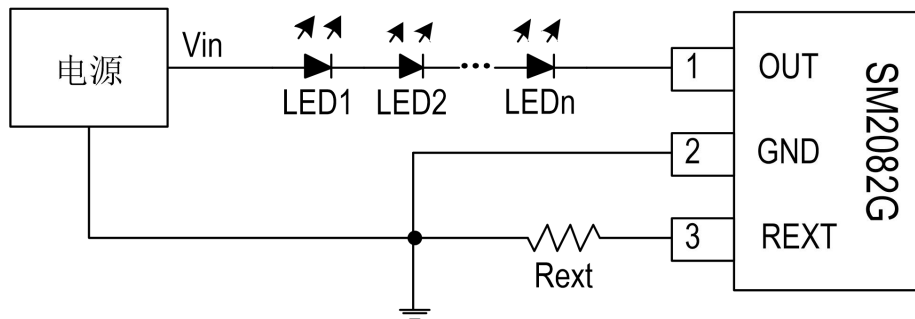

Figure 1. SM2082G application circuit schematic diagram

### ◆ efficiency design theory

The operating efficiency of the application circuit shown in Figure 1 is calculated as follows:

$$\eta = \frac{P_{LED}}{P_{IN}} = \frac{n * V_{LED} * I_{LED}}{V_{IN} * I_{LED}} = \frac{n * V_{LED}}{V_{IN}}$$

Where  $V_{in}$  is the system input power supply voltage,  $V_{LED}$  is the operating voltage drop of a single LED, and  $I_{LED}$  is the average LED current. It can be seen that the larger the number  $n$  of LEDs connected in series in the system, the higher the working efficiency of the system.

During the system design process, the working voltage of the OUT port of SM2082G needs to be adjusted according to the application environment and the eta value should be optimized.

### ◆ LED series quantity design

The design of the number of LEDs connected in series in the system needs to consider the following two aspects:

- 1) In the circuit of Figure 1 , the OUT port voltage  $V_{OUT} = V_{in} - n * V_{LED}$  . To ensure the normal operation of the chip, it is necessary to ensure that the OUT port voltage  $V_{OUT} \geq V_{OUT\_MIN}$  ;
- 2) The lower the voltage of the chip OUT port, the higher the system efficiency.

Based on the above two points, the number  $n$  of LEDs connected in series in the system is calculated as:

$$n = \frac{V_{in} - V_{out}}{V_{LED}}$$

## Typical Application Description

### ◆ Single chip application instructions

Figure 2 is the circuit diagram of the SM2082G AC power supply application solution. The LED lights can be connected in series, parallel or a combination of series and parallel; C1 is an electrolytic capacitor, used to reduce the  $V_{in}$  voltage ripple; the Rext resistor is used to set the operating current of the LED light.

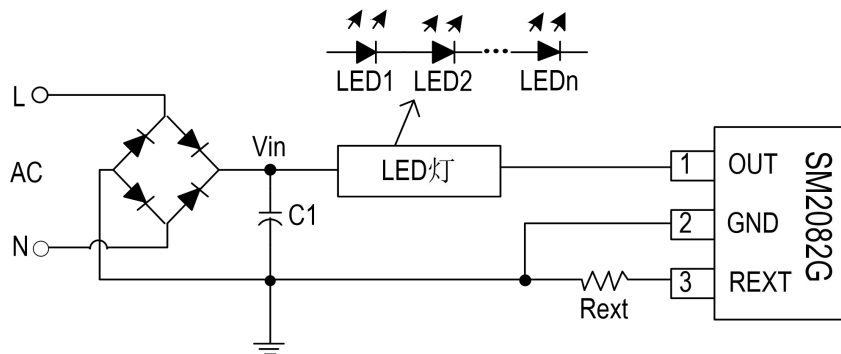

Figure 2. SM2082G typical application circuit—AC power input

electrolytic capacitor C 1 is, the smaller the voltage  $V_{in}$  ripple is, and the smaller the SM2082 G OUT port voltage ripple is. The C 1 value is determined based on the total operating current of the LED lamp: the greater the current, the greater the C 1 capacitance value. The specific calculation method is as follows:

$$\text{Capacitance value of } C1 = \frac{I_{LED} * t}{\Delta V} \text{ filter capacitor } C1 :$$

In the formula,  $I_{LED}$  is the average current in the entire solution , time  $t$  : approximately  $(1/4) * (1/f_{AC}) = 5ms$  at 50Hz , and  $\Delta V$  is the OUT port voltage ripple.

### ◆ Chip parallel application instructions

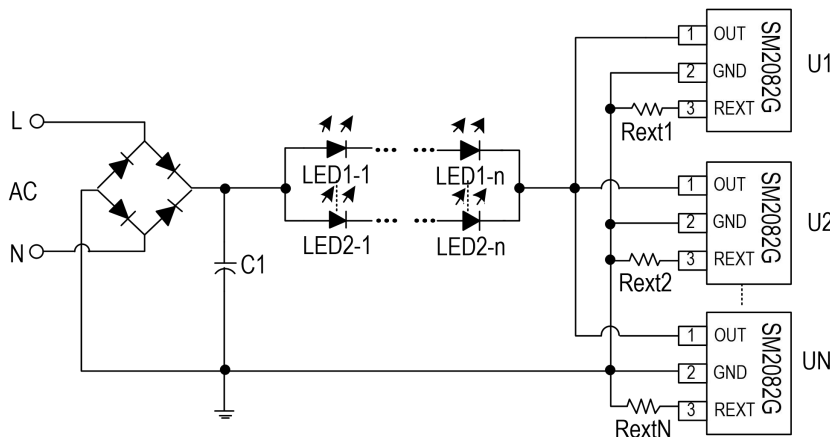
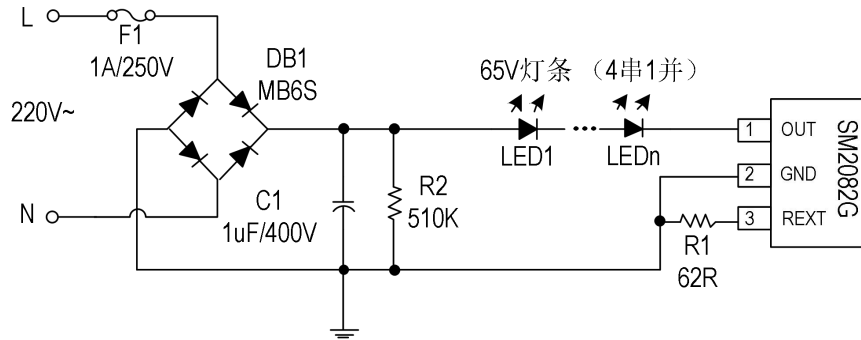

Figure 3. SM2082G parallel application circuit schematic diagram

Select the number of parallel chips according to the operating current of the LED lamp. It is recommended that the resistance values of Rext1~Rext (n+1) in the figure be set to the same value to ensure that the average current of each channel is evenly distributed .

## Typical Application

### ◆ Solution 1 SM2082G SOT89-3 package flicker-free application solution (3W)



1. It is recommended that the LED light string voltage be controlled between 250V and 270V to optimize system operation.
2. By changing the resistance value of R1, adjust the output operating current value.

### ◆ Solution 2 SM2082G TO252 package flicker-free application solution (16W)

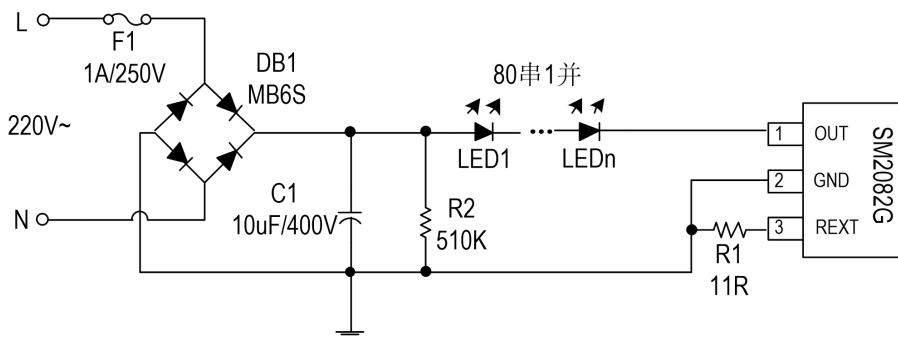

1. It is recommended that the LED light string voltage be controlled between 250V and 270V to optimize system operation.
2. By changing the resistance value of R1, adjust the output operating current value.

### ◆ Solution 3 SM2082G TO252 package thyristor dimming application solution (12W)

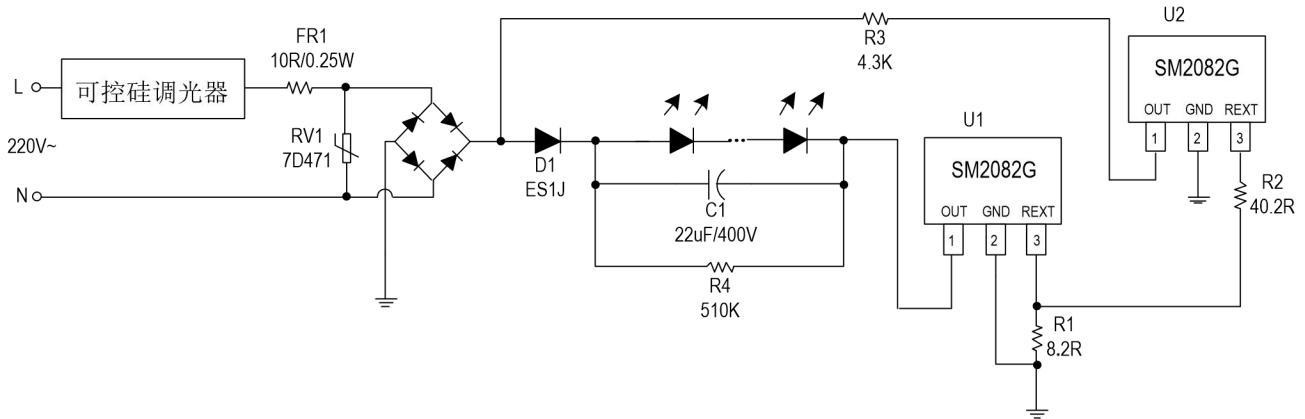

1. It is recommended that the LED light string voltage be controlled between 230V and 250V to optimize system operation.
2. By changing the resistance value of R1, the output operating current value is adjusted, and by changing the resistance value of R2, the discharge current value is adjusted.
3. R3 is a 1W power resistor, used to reduce the power consumption of U2 SM2082G.

## Packaging Welding Process

The semiconductor products produced by SUNMOON comply with the European RoHs standard, and the soldering furnace temperature of the packaging and welding process complies with the J-STD-020 standard.

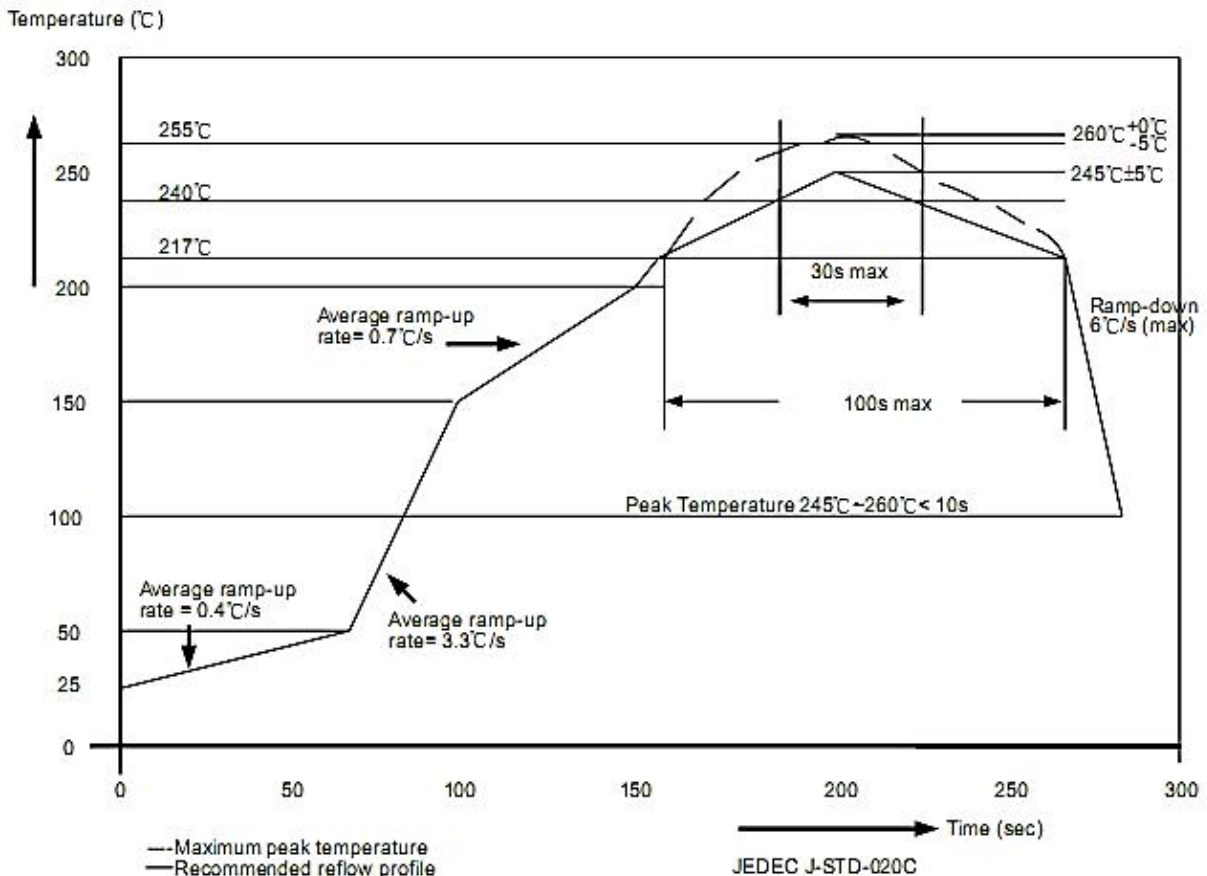



Package thickness	volume mm <sup>3</sup> < 350	volume mm <sup>3</sup> : 350~2000	volume mm <sup>3</sup> ≥ 2000
<1.6mm	260+0 °C	260+0 °C	260+0 °C
1.6mm~2.5mm	260+0 °C	250+0 °C	245+0 °C
≥ 2.5mm	250+0 °C	245+0 °C	245+0 °C



## Package Form

TO252-2

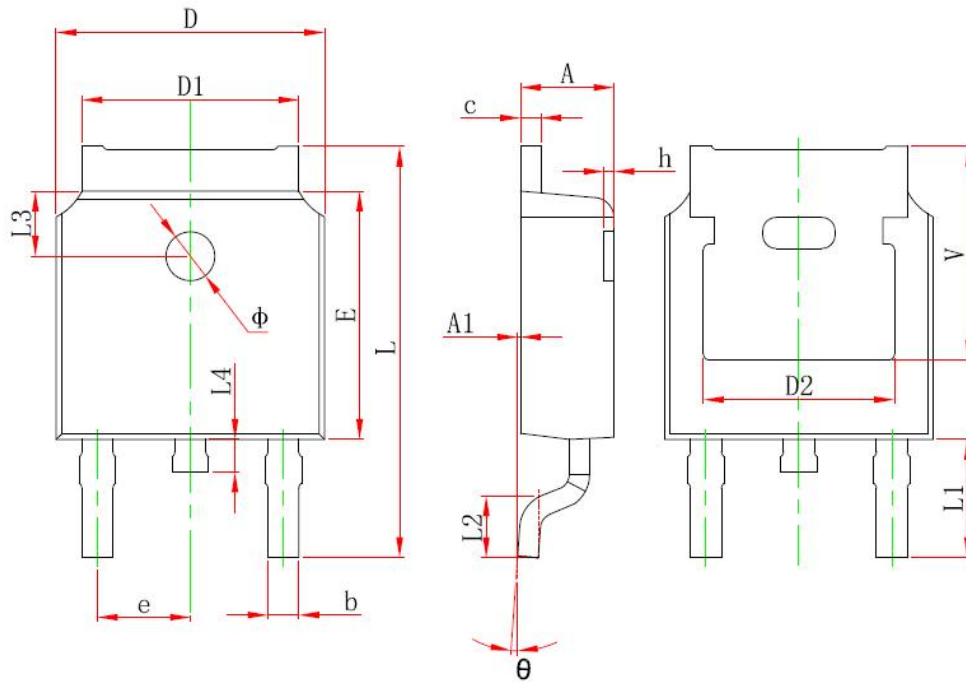

Symbol	Min(mm)	Max(mm)
A	2.0	2.7
A1	-	0.2
b	0.5	1.1
c	0.3	0.8
D	6.3	6.9
D1	4.9	5.7
D2	4.83(REF)	
E	5.9	6.4
e	2.086	2.486
L	9.5	10.7
L1	2.9(REF)	
L2	1.2	1.9
L3	1.6(REF)	
L4	0.4	1.2
φ	0.9	1.5
θ	0°	10°
h	-	0.5
V	5.35(REF)	

SOT89-3

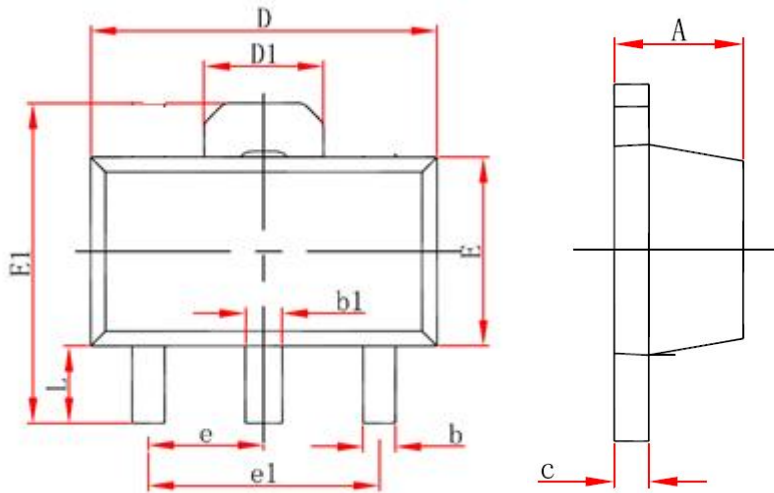

Symbol	Min(mm)	Max(mm)
A	1.3	1.8
b	0.2	0.7
b 1	0.25	0.75
c	0.2	0.6
D	4.3	4.8
E	2.2	2.8
E1	3.8	4.5
D1	1.55(REF)	
e	1.5(TYP)	
e 1	3.0(TYP)	
L	0.8	1.5

## Manual Revision Record

Date	Manual version	Introduction to the revised content
2016-3-11	QZOOIGV1.0	First edition of the instruction manual
2023-5-30	QZZQZWW2.0	Change the number of TO252-2 package tapes, P2
2023-6-15	QZZQZWW2.1	Revised electrical parameters, P3

## Declaration

Sunmoon owns the right of, alteration, correction, modification, improvement and termination about our products, files and services. To the rights above, recommend customers to contact our business representative for the latest product information before purchasing. All technical applications need to be designed in strict accordance with the latest product specifications.

Sunmoon electronic products cannot be used in medical or military areas without our legal authorization. If users get injured or life threat even to dead, we are not responsible for any damage.

All verbal content, pictures and trademark are intellectual property of Sunmoon. Any individuals and organizations cannot use, correct, redo, public, remake, spread, publish or vend it to damage the legitimate rights and interests of Sunmoon, For the relevant infringement, we will immediately start a full legal process, held accountable.